



New! Highest Security Mailboxes

Horizontal Mailbox



- * **Approved by New York City's Housing Authority**, exceeding the country's strictest requirements.
- * Built solid with a 1/4" aluminum door and the **safeguard locking system**, protecting all sides.
- * **Added protection** with continuous hinge and locking bar on all front loads.

Security's safeguard locking system
view from back side of door

- * **USPS Approved**
surpassing USPS highest security guidelines
- * Integral Trim for **durability** and **easy installation**.
- * **State of the Art**
powder coat paint.

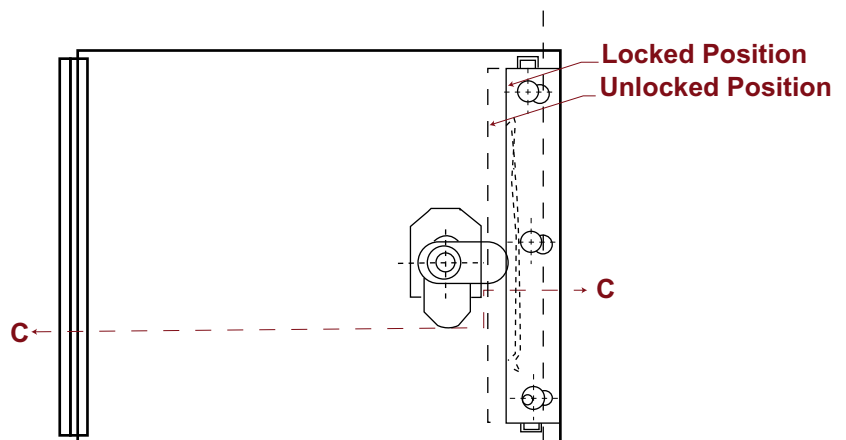

U.S. Patent Applied

Security Manufacturing now has the highest security mailbox available! Contact us to receive information on the new safeguard locking system at the best prices.